



INSTALLATION, OPERATION, AND MAINTENANCE MANUAL
WELKER CONSTANT PRESSURE CYLINDER

MODEL
CP-80

DRAWING NUMBERS
AD871B0
AD871BP

MANUAL NUMBER
IOM-110

REVISION
Rev. B, 6/7/2018

TABLE OF CONTENTS

	SAFETY	3
1.	PRODUCT INFORMATION	4
1.1	Introduction	4
1.2	Product Description	4
1.3	Safety Warning and Important Information	5
1.4	Specifications	6
1.5	Equipment Diagram	7
2.	INSTALLATION & OPERATION	8
2.1	Before You Begin	8
2.2	Pre-Charging the CP-80	8
2.3	Installation	12
2.4	Spot Sampling From a Pressurized Source	13
2.5	Continuous Sampling	13
3.	MAINTENANCE	15
3.1	Before You Begin	15
3.2	Leak Testing the CP-80	15
3.3	Purging and Decontaminating the CP-80	16
3.4	Maintenance	17
3.5	Troubleshooting	21
	APPENDICES	22
	A: Referenced or Attached Documents	22
	B: CP-80 With Vortex Mixer	23

IMPORTANT SAFETY INFORMATION

READ ALL INSTRUCTIONS



Notes emphasize information and/or provide additional information to assist the user.



Caution messages appear before procedures that could result in damage to equipment if not observed.



Warning messages appear before procedures that could result in personal injury if not observed.

This manual is intended to be used as a basic installation and operation guide for the Welker Constant Pressure Cylinder, CP-80. For comprehensive instructions, please refer to the IOM Manuals for each individual component. A list of relevant component IOM Manuals is provided in Appendix A of this manual.

The information in this manual has been carefully checked for accuracy and is intended to be used as a guide for the installation, operation, and maintenance of the Welker equipment described in this manual. Correct installation and operation, however, are the responsibility of the end user. Welker reserves the right to make changes to this manual and all products in order to improve performance and reliability.

BEFORE YOU BEGIN

Read these instructions completely and carefully.

IMPORTANT - Save these instructions for local inspector's use.

IMPORTANT - Observe all governing codes and ordinances.

Note to Installer - Leave these instructions with the end user.

Note to End User - Keep these instructions for future reference.

Installation of this Constant Pressure Cylinder is of a mechanical nature.

Proper installation is the responsibility of the installer. Product failure due to improper installation is not covered under the warranty.

If you received a damaged Constant Pressure Cylinder, please contact a Welker representative immediately.

Phone: 281.491.2331

Address: 13839 West Bellfort Street
Sugar Land, TX 77498

1.1 Introduction

We appreciate your business and your choice of Welker products. The installation, operation, and maintenance liability for this equipment becomes that of the purchaser at the time of receipt. Reading the applicable *Installation, Operation, and Maintenance (IOM) Manuals* prior to installation and operation of this equipment is required for a full understanding of its application and performance prior to use.*

If you have any questions, please call Welker at 1-281-491-2331.

**The following procedures have been written for use with standard Welker parts and equipment. Assemblies that have been modified may have additional requirements and specifications that are not listed in this manual.*

1.2 Product Description

The Welker *CP-80* Constant Pressure Cylinder is designed to contain and transfer accurate samples or calibration standards for laboratory analysis.

Contents are maintained under full pipeline pressure by pre-charging the CP-80 with an inert gas or pipeline gas. Filling a pre-charged cylinder protects against phase change and maintains the sample's integrity by collecting sample at full line pressure. End caps with valves, gauges, and relieving devices enable the cylinder pressure to be controlled and monitored at all times.

The internal floating piston plays a key role in volume indication and contamination prevention. As the cylinder is filled and the piston moves inside the cylinder, the piston magnet pulls the tracker magnet along the graduated scale, allowing the operator to monitor the product level within the cylinder. As the cylinder is emptied, the piston wipes the cylinder walls clean and forces any air and/or contaminants from the cylinder, preventing cross-contamination between samples.

The optional vortex mixer is recommended for high viscosity products and products that stratify. The sample is mixed manually by pushing down and pulling up on the T-handle of the mixing rod. This manual mixing action creates a vortex or spiral movement in the sample. The vortex causes a pressure drop at the center of the cylinder, which pulls the stratified product toward the middle, thoroughly mixing the entire sample inside the cylinder to provide a uniform mix prior to analysis.



The Welker CP-80 **does not** carry a DOT special permit. For a DOT-approved Welker Constant Pressure Cylinder, please contact a Welker representative.

Welker may custom design the CP-80 to suit the particular application and specifications of each customer.

1.3 Safety Warning and Important Information



Please read the following information in its entirety before using the Welker equipment described in this manual. Failure to adhere to these recommendations may result in equipment damage or personal injury.

General

1. Product expansion may occur if the sample cylinder is subjected to extreme temperature changes. Operators should be familiar with the physical properties of the sampled product and should be able to adequately estimate the expansion potential of the product. Certain products may require a greater proportion of inert gas to product (e.g., 40% inert gas to 60% product) to allow ample room for product expansion.
2. In cases where the sample cylinder is exposed to extreme or varying temperatures, do not allow the sample cylinder to exceed the maximum allowable operating pressure (MAOP) indicated in *Section 1.4, Specifications*.
3. Handle the sample cylinder with caution. The sample cylinder is a precision instrument and may contain flammable or hazardous product.
4. Welker recommends that the sample cylinder be purged and leak tested after each use and that the sample cylinder valves be capped or plugged during transit and when not in use.
5. Prior to plugging or capping valves, ensure that any residual liquids have been drained, purged, or absorbed from the accessible exterior dead volume of the valve body.
6. When analysis of the product is complete, the sample cylinder should be safely emptied.

Calibration Standards and Laboratory Use



For specific instructions on calibration, testing, and/or analysis, refer to the appropriate standard(s).

1. To preserve the integrity of the sample cylinder contents, pre-charge pressure equal to the starting pressure in the sample cylinder must be applied and maintained when sending calibration standards and/or the collected sample to the analyzer.



Applying and maintaining pre-charge pressure while emptying the sample cylinder prevents the original composition and phase state of the calibration standard and collected sample from changing.

2. Sample cylinders used for calibration standards may require mixing to thoroughly blend the calibration standard and ensure even distribution of components or heating to prevent the calibration standard from falling below its dew point.
3. After being emptied, sample cylinders used for calibration standards should be cleaned and maintained and then properly conditioned and prepared prior to reuse.

1.4 Specifications



The specifications listed in this section are generalized for this equipment. Welker can modify the equipment according to your company's needs. **Please note that the specifications may vary depending on the customization of your equipment.**

Table 1: CP-80 Specifications

Products Sampled	Gases and Liquids Compatible With the Materials of Construction
Materials of Construction	316/316L Stainless Steel, PTFE, and Viton® Others Available
Maximum Allowable Operating Pressure	5000 psig @ -20 °F to 100 °F (344 barg @ -28 °C to 37 °C)
Connections	Pre-Charge Inlet: ¼" FNPT Product Inlet: ¼" FNPT Purge Outlet (Optional): ¼" FNPT
Volume	2000 cc 2250 cc 6000 cc Others Available
Features	Burst Discs Pressure Gauges Valves
Options	Purge Valve Quick-Connects on Product Side Vortex Mixer NACE Compliance

1.5 Equipment Diagram

Figure 1: Standard CP-80 Diagram

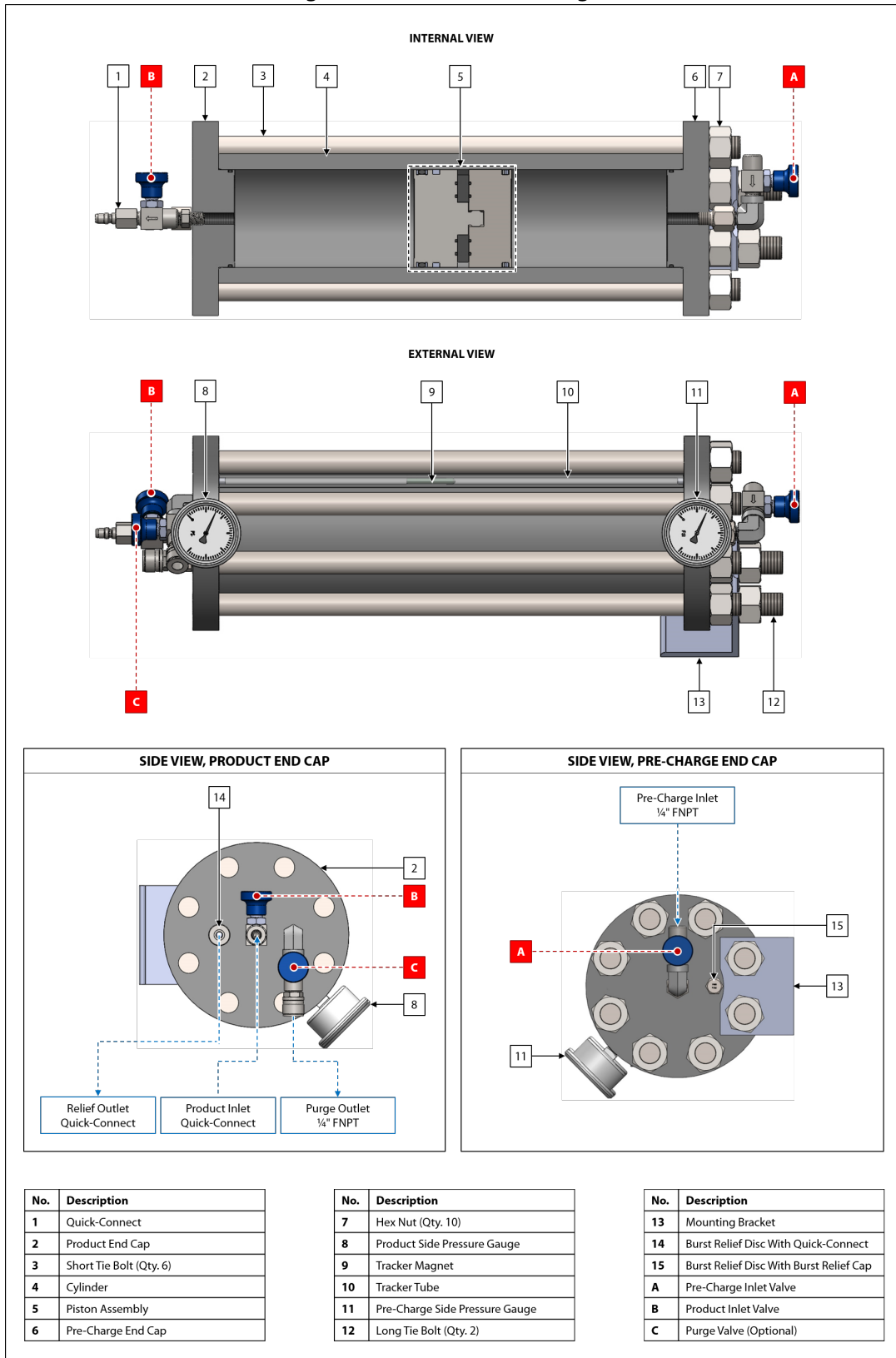

SECTION 2: INSTALLATION & OPERATION

2.1 Before You Begin



After unpacking the unit, check the equipment for compliance and any damage that may have occurred during shipment. Immediately contact a Welker representative if you received damaged equipment.



When sealing fittings with PTFE tape, refer to the proper sealing instructions for the brand used.

2.2 Pre-Charging the CP-80



The relief valves and gauges must be adequate for the pressure used to pre-charge the CP-80.



The gas used to pre-charge the CP-80 must be compatible with the cylinder seals.



If the CP-80 will be pre-charged using pipeline product, continue to step 1.
If the CP-80 will be pre-charged using returned product, proceed to step 12.
If the CP-80 will be pre-charged using an auxiliary gas, proceed to step 22.

Using Pipeline Product



This method should only be used if connecting to a pressurized gas pipeline.



A CP-80 with vortex mixer should not be pre-charged using pipeline product.

1. Ensure that all valves on the CP-80 are closed (*Figure 1*).
2. As necessary, install an adjustable relief valve to the pre-charge end cap.



If the CP-80 will be used for continuous sampling but will not remain connected to the pre-charge source, an adjustable relief valve is required to relieve pre-charge pressure during continuous sampling.

3. Using small diameter tubing, connect from an available pipeline isolation valve to pre-charge inlet valve A (*Figure 1*).
4. Open the pipeline isolation valve.
5. Slowly open pre-charge inlet valve A (*Figure 1*). The piston inside the CP-80 should begin to move toward the product end cap, as indicated by the magnetic volume indicator or indicator rod.



Once the pre-charge pressure gauge begins to read pressure, do not open the valve any further. The cylinder should be pre-charged slowly and smoothly. Opening the valve too quickly or too much may cause the piston to slam from one end of the cylinder to the other and may result in damage to the unit.

6. Slowly open product inlet valve B to relieve any pressure from the product side of the CP-80 (*Figure 1*).
7. Once pressure has been relieved from the product side of the CP-80, close product inlet valve B (*Figure 1*).
8. Fill the pre-charge side of the CP-80 until the magnetic volume indicator or indicator rod indicates 0% and the pre-charge pressure gauge indicates pipeline pressure.
9. Once the CP-80 has been pre-charged, close all valves and check for leaks.
10. Disconnect the tubing between the pipeline isolation valve and pre-charge inlet valve A.
11. Proceed to *Section 2.3, Installation*.

Using Returned Product



This method should only be used for continuous sampling of a pressurized gas pipeline.

12. Ensure that all valves on the CP-80 are closed (*Figure 1*).
13. As necessary, install a valve to the return port on the probe.
14. Using small diameter tubing, connect from the return valve on the probe to pre-charge inlet valve A (*Figure 1*).
15. Open the return valve on the probe.
16. Slowly open pre-charge inlet valve A (*Figure 1*). The piston inside the CP-80 should begin to move toward the product end cap, as indicated by the magnetic volume indicator or indicator rod.



Once the pre-charge pressure gauge begins to read pressure, do not open the valve any further. The cylinder should be pre-charged slowly and smoothly. Opening the valve too quickly or too much may cause the piston to slam from one end of the cylinder to the other and may result in damage to the unit.



Pre-charge inlet valve A and the return valve on the probe must remain open during pre-charging and continuous sampling.

17. Slowly open product inlet valve B to relieve any pressure from the product side of the CP-80 (*Figure 1*).
18. Once pressure has been relieved from the product side of the CP-80, close product inlet valve B (*Figure 1*).
19. Fill the pre-charge side of the CP-80 until the magnetic volume indicator or indicator rod indicates 0% and the pre-charge pressure gauge indicates pipeline pressure.
20. Once the CP-80 has been pre-charged, check for leaks.
21. Proceed to *Section 2.3, Installation*.

Using an Auxiliary Gas



The auxiliary gas used to pre-charge the CP-80 must be regulated to 50–100 psig above pipeline pressure, not to exceed the maximum allowable operating pressure (MAOP) of the cylinder.



Welker recommends using nitrogen or helium as the inert gas supply.

22. Ensure that all valves on the CP-80 are closed (*Figure 1*).
23. As necessary, install an adjustable relief valve to the pre-charge end cap.



If the CP-80 will be used for continuous sampling but will not remain connected to the pre-charge source, an adjustable relief valve is required to relieve pre-charge pressure during continuous sampling.

24. Using small diameter tubing, connect from the auxiliary gas supply to pre-charge inlet valve A (*Figure 1*).
25. Open the valve on the auxiliary gas supply.
26. Slowly open pre-charge inlet valve A (*Figure 1*). The piston inside the CP-80 should begin to move toward the product end cap, as indicated by the magnetic volume indicator or indicator rod.



Once the pre-charge pressure gauge begins to read pressure, do not open the valve any further. The cylinder should be pre-charged slowly and smoothly. Opening the valve too quickly or too much may cause the piston to slam from one end of the cylinder to the other and may result in damage to the unit.

27. Slowly open product inlet valve B to relieve any pressure from the product side of the CP-80 (*Figure 1*).
28. Once pressure has been relieved from the product side of the CP-80, close product inlet valve B (*Figure 1*).
29. Fill the pre-charge side of the CP-80 until the magnetic volume indicator or indicator rod indicates 0% and the pre-charge pressure gauge indicates the pressure of the regulated auxiliary gas (i.e., 50–100 psig above pipeline pressure but not exceeding the maximum allowable operating pressure (MAOP) of the CP-80).
30. Once the CP-80 has been pre-charged, close all valves and check for leaks.
31. Disconnect the tubing between the auxiliary gas supply and pre-charge inlet valve A.
32. Continue to *Section 2.3, Installation*.

2.3 Installation

1. As necessary, ensure that an adjustable relief valve has been installed to the pre-charge end cap.



If the CP-80 will be used for continuous sampling but will not remain connected to the pre-charge source, an adjustable relief valve is required to relieve pre-charge pressure during continuous sampling.

2. If the CP-80 requires an adjustable relief valve, set the relief valve 50–100 psig above pipeline pressure, not to exceed the maximum allowable operating pressure (MAOP) of the cylinder. Refer to the *Installation, Operation, and Maintenance (IOM) Manual* for the relief valve for instructions on setting the relief.
3. If the CP-80 is not equipped with a purge valve, tube a T-fitting and valve inline between the sample point and the CP-80 to provide a means by which the system can be purged.
4. Ensure that all valves on the CP-80 are closed (*Figure 1*).
5. Install the CP-80 as close to the sample point as possible.
6. Using small diameter tubing, connect from the sample point (i.e., the probe or sampler outlet) to product inlet valve B (*Figure 1*).

Purging the CP-80



Welker recommends that the sample cylinder be cleaned or purged prior to each sample batch to remove any air and/or old product from the system and prevent cross-contamination between samples.

7. Connect from purge valve C to a drain, flare, or safe ventilation area (*Figure 1*).
8. Open product inlet valve B, and then open purge valve C (*Figure 1*).
9. Pressure from the sample point will cause air and/or old product to purge from the sample line.



During the purge cycle, the product pressure gauge will indicate a pressure drop.

10. Allow approximately 5–10 seconds for air and/or old product to purge.
11. Once purging is complete, close product inlet valve B, and then close purge valve C (*Figure 1*).
12. Disconnect purge valve C from the drain, flare, or safe ventilation area.



Welker recommends plugging the purge valve when not in use.

13. Sampling may now begin. For spot sampling procedures, continue to *Section 2.4, Spot Sampling From a Pressurized Source*. For continuous sampling procedures, proceed to *Section 2.5, Continuous Sampling*.

2.4 Spot Sampling From a Pressurized Source

1. Ensure that the CP-80 has been adequately pre-charged.
2. Ensure that the CP-80 has been purged.
3. Ensure that product inlet valve B is connected to the sample point (i.e., the probe or sampler outlet).
4. Slowly open the outlet valve on the probe or sampler.
5. Slowly open product inlet valve B (*Figure 1*). The piston will not yet move because pre-charge pressure is at or above pipeline pressure.
6. With the outlet valve and product inlet valve B fully open, slowly open pre-charge inlet valve A to relieve pre-charge pressure (*Figure 1*).



Relieving pre-charge pressure too quickly can result in a pressure drop and an inaccurate sample. A bleed plug can be installed to pre-charge inlet valve A to regulate the relieving rate. By allowing only a small amount of pressure to exit, the bleed plug ensures that pre-charge pressure is relieved steadily.

7. Continue sampling until the desired volume of sample has been obtained.



For liquid products, never fill the cylinder above 80% of its capacity. Allow at least 20% room for product expansion should the cylinder be exposed to increased temperatures. Note that certain products may require a greater proportion of inert gas to product.

8. Once the desired volume of sample has been obtained, close pre-charge inlet valve A, product inlet valve B, and the outlet valve on the probe or sampler (*Figure 1*).
9. Carefully disconnect the CP-80 from the probe or sampler, allowing product trapped between the CP-80 and the probe or sampler to vent.



It is the responsibility of the end user to determine how best to vent product trapped between the CP-80 and the sample source prior to disconnection. Failure to vent trapped product could prevent disconnection or cause injury to the operator.

10. Plug or cap all valves on the CP-80.



Female valves are typically plugged.
Male valves are typically capped.

11. Label the filled CP-80 and prepare it for transfer to the testing laboratory in accordance with company policy.

2.5 Continuous Sampling



If the CP-80 will be used for continuous sampling of liquids, a means of relieving pre-charge pressure during sampling must be provided. If the CP-80 will remain connected to the pre-charge source, open the valve on the pre-charge source prior to continuous sampling. If the CP-80 will not remain connected to the pre-charge source, an adjustable relief valve is required.

1. As necessary, ensure that an adjustable relief valve has been installed to the pre-charge end cap.



If the CP-80 will be used for continuous sampling but will not remain connected to the pre-charge source, an adjustable relief valve is required to relieve pre-charge pressure during continuous sampling.

2. Ensure that the CP-80 has been pre-charged.
3. Ensure that the CP-80 has been purged.
4. Ensure that product inlet valve B is connected to the sample point (i.e., the sampler outlet).
5. If the CP-80 is connected to the pre-charge source, ensure that pre-charge inlet valve A is open.



Pre-charge inlet valve A and the return valve on the probe must remain open during pre-charging and continuous sampling.

6. Slowly open the outlet valve on the sampler.
7. Slowly open product inlet valve B (*Figure 1*). The piston will not yet move because pre-charge pressure is at or above pipeline pressure.



During continuous sampling, the automatic sampler will push product against the piston, causing pre-charge pressure to relieve from the adjustable relief and/or be returned to the pipeline.

8. Begin sampling and continue until the desired volume of sample has been obtained.



For liquid products, never fill the cylinder above 80% of its capacity. Allow at least 20% room for product expansion should the cylinder be exposed to increased temperatures. Note that certain products may require a greater proportion of inert gas to product.

9. Once the desired volume of sample has been obtained, halt sampling.
10. Close pre-charge inlet valve A, product inlet valve B, and the sampler outlet valve (*Figure 1*).
11. Carefully disconnect the CP-80 from the sampler, allowing product trapped between the CP-80 and the sampler to vent.



It is the responsibility of the end user to determine how best to vent product trapped between the CP-80 and the sample source prior to disconnection. Failure to vent trapped product could prevent disconnection or cause injury to the operator.

12. Plug or cap all valves on the CP-80.



Female valves are typically plugged.
Male valves are typically capped.

13. Label the filled CP-80 and prepare it for transfer to the testing laboratory in accordance with company policy.

3.1 Before You Begin

1. **Welker recommends that the unit have standard maintenance any time the CP-80 will be used to contain a different product.**
2. **Welker recommends that the unit have standard maintenance under normal operating conditions:** for *gas sampling* every six (6) months; and for *liquid sampling* every twelve (12) months. In cases of severe service, dirty conditions, excessive usage, or other unique applications that may lead to excess wear on the unit, a more frequent maintenance schedule may be appropriate.
3. Prior to maintenance or disassembly of the unit, it is advisable to have a repair kit available for repairs of the system in case of unexpected wear or faulty seals.



New seals supplied in spare parts kits should be lightly lubricated before being installed to ease the installation of the seals and reduce the risk of damage when positioning them on parts. Wipe excess lubricant from the seals, as it may adversely affect analytical instrument results.



For sample-exposed seals, Welker recommends non-hydrocarbon-based lubricants, such as Krytox®. For non-sample-exposed seals, Welker recommends either non-hydrocarbon-based lubricants or silicone-based lubricants, such as Molykote® 111.

4. All maintenance and cleaning of the unit should be performed on a smooth, clean surface.
5. Welker recommends having the following tools available for maintenance. Please note that the exact tools required may vary by model.
 - a. Channel Lock Pliers
 - b. Flat Head Screwdriver
 - c. Hex Key Set
 - d. Seal Pick
 - e. Strap Wrench
 - f. Torque Wrench

3.2 Leak Testing the CP-80



Welker recommends leak testing the CP-80 after each use.

1. Slowly apply inert gas to the product end of the CP-80 until the piston is at the pre-charge end cap. Check for leaks in the product-side fittings and repair as necessary.
2. Open pre-charge inlet valve A to check for leaks across the piston. Repair as necessary.
3. Relieve pressure from the product side of the CP-80.
4. Slowly apply inert gas to the pre-charge end of the CP-80 until the piston is at the product end cap. Check for leaks in the pre-charge side fittings and repair as necessary. Note that this will pre-charge the CP-80.
5. Open product inlet valve B to check for leaks across the piston. Repair as necessary.

3.3 Purging and Decontaminating the CP-80



Take the necessary precautions and wear appropriate personal protective equipment (PPE) to protect from potential harm caused by the sampled product.



Regular cleaning of the sample cylinder is essential for proper functioning of the unit. For cylinders used for sample containment, any debris or residue left in the sample cylinders may contaminate the results of later samples collected in the sample cylinders.

Purging

Purging With Nitrogen

1. Fill the CP-80 with clean, dry nitrogen, and then empty the cylinder. Repeat several times.
2. Fill the CP-80 with helium, and then take a sample of the helium and test it for trace amounts of hydrocarbons.
3. If hydrocarbons and/or contaminants are present in the analysis, the CP-80 has not been adequately cleaned and further purging of the sample cylinder is necessary; repeat steps 1 and 2. If hydrocarbons and/or contaminants remain present after repeating steps 1 and 2, it may be necessary to decontaminate the CP-80 with solvent.
4. Purging is complete when no hydrocarbons and/or contaminants are present in the analysis.

Purging With New Product

Purge the CP-80 with the product to be sampled. This can be accomplished each time the CP-80 is put into service. See *Section 2.3, Installation*, for instructions on purging the CP-80 with new product.



This method is only advisable if the sample cylinder will be used in the same location to sample the same type of product.

Decontaminating With Solvent

1. Repeatedly flush the CP-80 with solvent.
2. Use clean, dry nitrogen to dry the CP-80.
3. Purge the CP-80 with nitrogen to remove any remaining solvent.
4. Fill the CP-80 with helium, and then take a sample of the helium and test it for trace amounts of solvent and hydrocarbons.
5. If solvent and/or hydrocarbons are present in the analysis, the CP-80 has not been adequately cleaned and further decontamination with solvent and/or purging of the CP-80 is necessary. Steps 1 and 2 may need to be repeated. Repeat steps 3 and 4.
6. Decontamination is complete when no solvent or hydrocarbons are present in the analysis.

3.4 Maintenance

1. If the CP-80 is equipped with the optional vortex mixer, refer to *Appendix B, CP-80 With Vortex Mixer*, for maintenance instructions.
2. Ensure that the CP-80 has been purged and/or decontaminated prior to performing maintenance. See *Section 3.3, Purging and Decontaminating the CP-80*, for instructions.
3. Ensure that the CP-80 has been disconnected from all pressure sources and depressurized prior to performing maintenance.

Disassembly

Figure 2: Standard CP-80 Maintenance Diagram

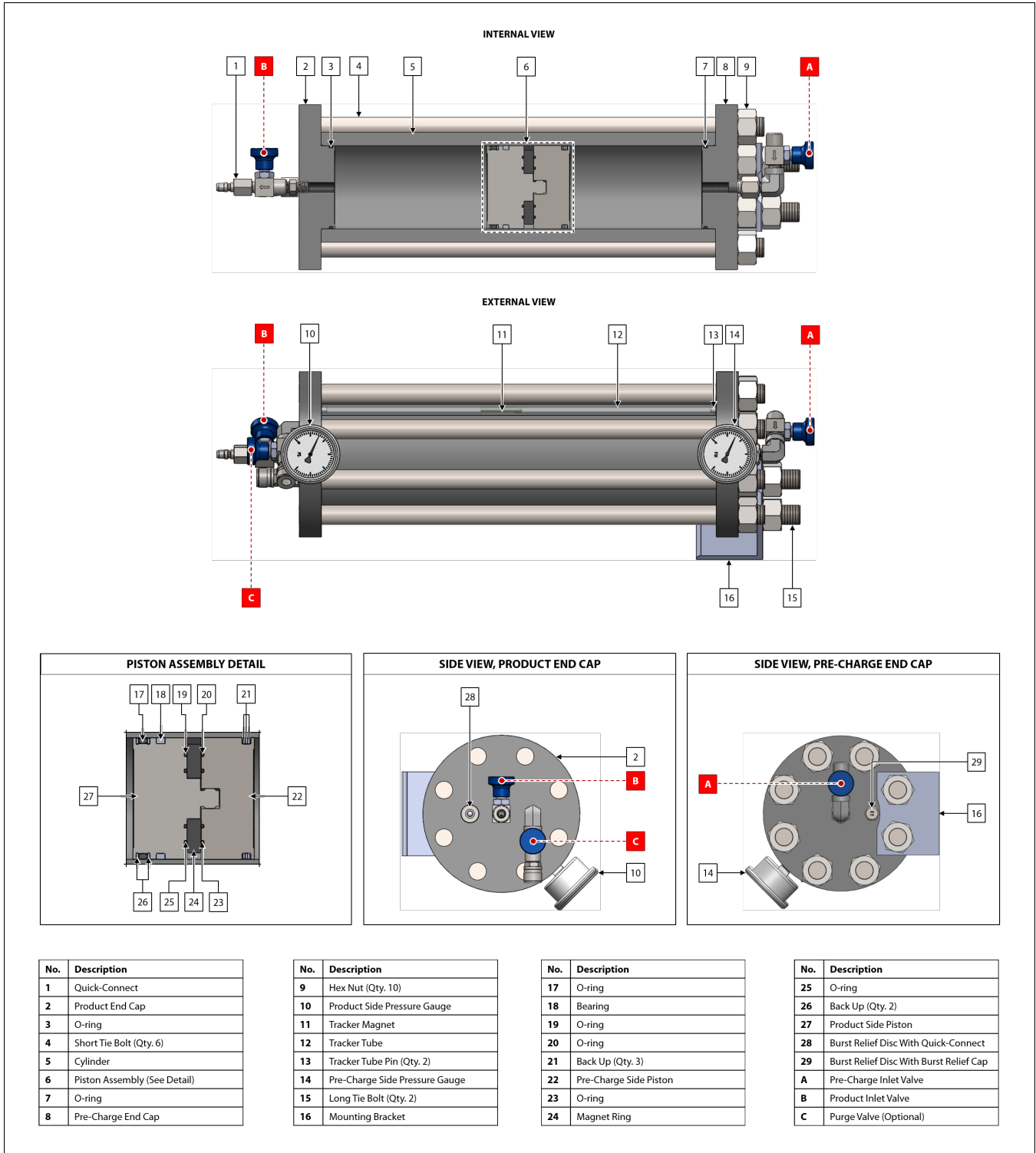

4. Remove the valves and pressure gauges from the end caps.
5. Unscrew the hex nuts, and then remove the pre-charge end cap from the cylinder.
6. Remove the tracker tube from the cylinder, taking care not to misplace the tracker tube pins or the tracker magnet.

7. Unscrew the tie bolts from the product end cap, and then remove the product end cap from the cylinder.
8. From the pre-charge side, slowly push the piston out of the cylinder. Note the position of the pre-charge and product side of the piston and cylinder for ease of reassembly.



As necessary, use a clean wooden dowel or PVC pipe to gently push the piston out of the cylinder. DO NOT use metal objects, as they may scratch and damage the unit.

End Caps

9. Remove the O-rings from the end caps.
10. Carefully clean and dry the end caps.
11. Install replacement O-rings to the end caps.
12. As necessary, maintain the valves and quick-connects. To perform maintenance on the valves, refer to the *Installation, Operation, and Maintenance (IOM) Manual* for the valves for instructions. To perform maintenance on the quick-connects, refer to the *Installation, Operation, and Maintenance (IOM) Manual* for the quick-connects for instructions.
13. If the CP-80 is equipped with burst relief discs, replace the burst relief discs. Refer to the *Installation, Operation, and Maintenance (IOM) Manual* for the burst relief discs for instructions.

Piston Assembly

14. Loosen the setscrew in the piston assembly, and then separate the three (3) parts of the piston assembly.
15. Remove the O-rings, back ups, and bearing on the pre-charge and product sides of the piston.
16. Carefully clean and dry the piston.
17. Install replacement back ups and O-rings to the pre-charge side of the piston, and then install a replacement bearing and replacement O-rings and back ups to the product side of the piston.
18. Reassemble the piston assembly, and then tighten the setscrew to secure the assembly.

Cylinder

19. Carefully wipe down and dry the inside of the cylinder.
20. Closely examine the polished and honed surfaces of the cylinder, as scratches or pits may cause the seals to leak. If scratches or pits are present, the unit may need to be repaired or replaced. Contact Welker for service options.

Reassembly

- 21. Insert the piston into the cylinder. Ensure that the pre-charge side of the piston is on the pre-charge side of the cylinder and that the product side of the piston is on the product side of the cylinder.
- 22. Install the cylinder to the product end cap.
- 23. Following a cross-bolting sequence, install the tie bolts to the product end cap (*Figure 3*). Note the two (2) long tie bolts must be installed so that the mounting bracket can be properly secured to them.

Figure 3: Cross-Bolting Sequence

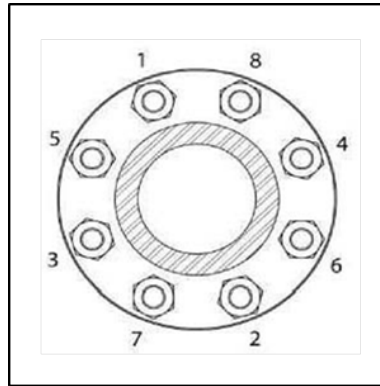

- 24. Ensure that the tracker magnet and tracker tube pins are inside the tracker tube.



If the tracker tube pins are not inside the tracker tube, the tracker magnet will fall below 0%, yielding an inaccurate reading.

- 25. Insert one end of the tracker tube into the product end cap.
- 26. Carefully install the pre-charge end cap to the cylinder. Ensure that the end cap fits onto the tracker tube and tie bolts.
- 27. Following a cross-bolting sequence, tighten the eight (8) hex nuts to the appropriate torque (*Figure 3* and *Table 2*).

Table 2: Torque Specifications for Tie Bolts

Tie Bolt Diameter	Foot-Pounds (ft•lb)	Kilograms per Meter (kg/m)
7/8" or 1"	55–65	7.60–8.98

- 28. Install the mounting bracket to the long tie bolts, and then install the remaining hex nuts to the top of the long tie bolts. Tighten firmly.
- 29. Return the valves and pressure gauges to the end caps.
- 30. Leak test the CP-80. See *Section 3.2, Leak Testing the CP-80*, for instructions.
- 31. Maintenance is now complete.

3.5 Troubleshooting

Table 3: CP-80 Troubleshooting		
Issues	Possible Causes	Solutions
A gauge indicates loss of pressure.	There is a leak from one of the fittings.	Use leak detector to check all fittings for leaks. Replace the thread sealant on the fittings.
	There is a leak from the burst discs.	Ensure that the burst discs are tightened to the proper torque. Refer to the <i>Installation, Operation, and Maintenance (IOM) Manual</i> for the burst discs for torque recommendations. If the problem persists, the burst discs may need to be replaced. If the lifespan of the burst discs has been exceeded, a more frequent preventative maintenance schedule may be required for the burst discs.
	The cylinder experienced a temperature drop.	Restore the temperature to pipeline temperature.
	There is a defective valve.	Refer to the <i>Installation, Operation, and Maintenance (IOM) Manual</i> for the valve for maintenance instructions.
Pressure is leaking across the piston.	The piston seals are leaking.	Disassemble and clean the CP-80. Inspect the cylinder for scratches. Replace seals on the piston, and then reassemble the CP-80. See <i>Section 3.4, Maintenance</i> , for maintenance instructions.
	There is a leak from the burst disc.	Ensure that the burst disc is tightened to the proper torque. Refer to the <i>Installation, Operation, and Maintenance (IOM) Manual</i> for the burst discs for torque recommendations. If the problem persists, the burst disc may need to be replaced. If the lifespan of the burst discs has been exceeded, a more frequent preventative maintenance schedule may be required for the burst discs.
The pre-charge or product end cap is leaking.	A fitting is loose.	Tighten the fitting.
	The seat on the purge valve is leaking.	Replace the seat on the purge valve.

APPENDIX A: REFERENCED OR ATTACHED DOCUMENTS

Welker *Installation, Operation, and Maintenance (IOM) Manuals* suggested for use with this unit:

- IOM-105: Welker NV-1 and NV-2 Instrument Valves

Other *Installation, Operation, and Maintenance (IOM) Manuals* suggested for use with this unit:

- Continental Disc Corporation Preparation and Installation of the ½" Standard Type Rupture Disc/Screw Type Holder Assembly (Welker IOM-V301)
- Swagelok Company Proportional Relief Valves R Series (Welker IOM-V086)
- Swagelok Company Quick-Connects QC, QF, QM, and QTM Series (Welker IOM-V088)
- WIKA Instrument Corporation Bourdon Tube Pressure Gauges Type 232.53 and Type 233.53 (Welker IOM-V171)

Welker drawings and schematics suggested for use with this unit:

- Assembly Drawing: AD871BO (Standard CP-80)
- Assembly Drawing: AD871BP (CP-80 With Vortex Mixer)

B1.1 Equipment Diagram

Figure B1: CP-80 With Vortex Mixer

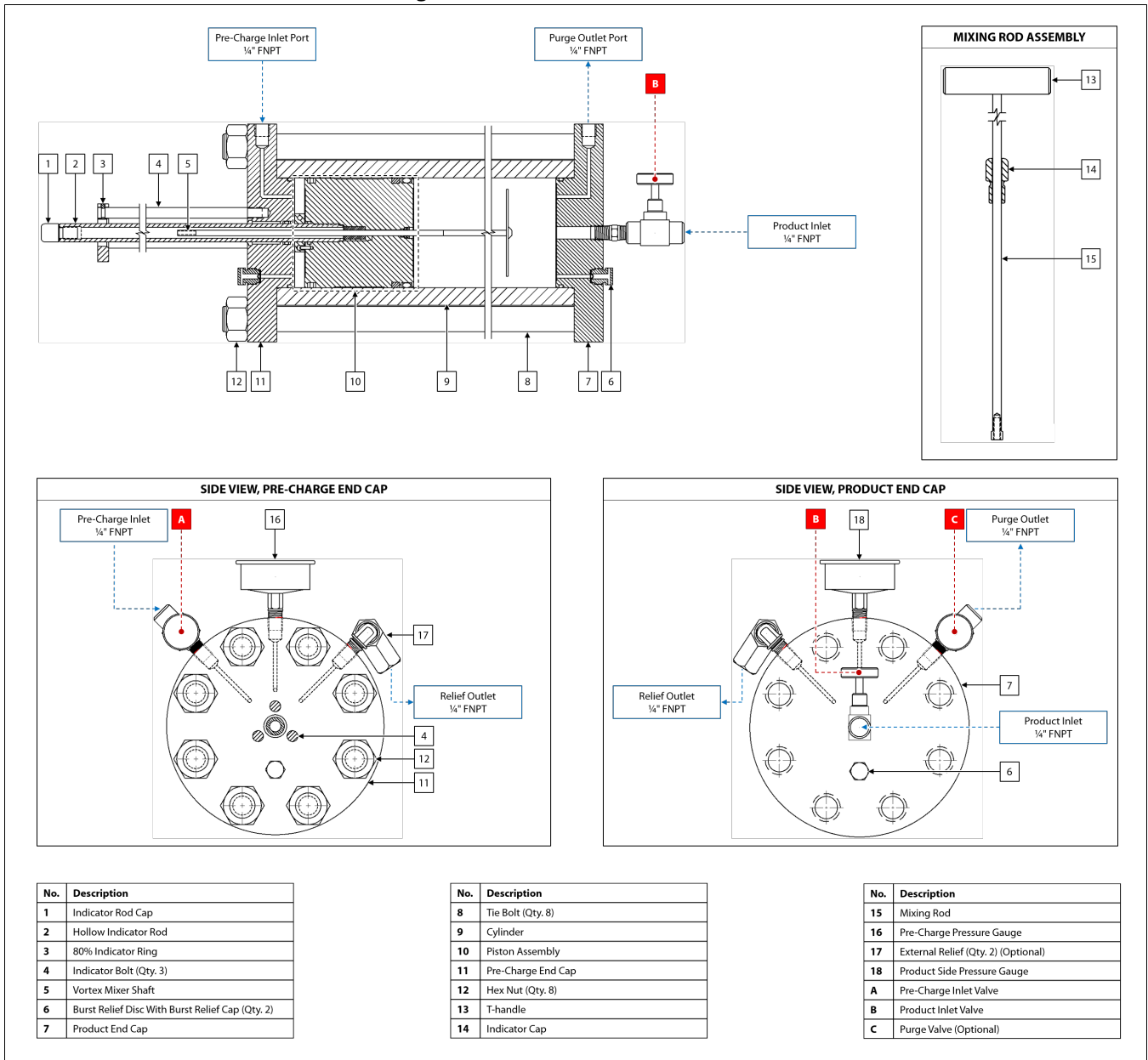

B1.2 Mixing the Sample

1. Remove the indicator rod cap from the hollow indicator rod.
2. Insert the mixing rod assembly into the hollow indicator rod. The bottom of the mixing rod should fit onto the vortex mixer shaft.
3. Screw the indicator cap into the hollow indicator rod. The mixing rod will screw onto the vortex mixer shaft.
4. Push down on the T-handle to push the vortex mixer shaft into the cylinder, and then pull up on the T-handle.
5. To ensure the sample is homogenous, repeat step 4 several (e.g., 5–10) times.
6. Once mixing is complete, unscrew the mixing rod assembly from the hollow indicator rod, and then return the indicator rod cap to the hollow indicator rod.

B1.3 Maintenance

1. Ensure that the CP-80 has been purged and/or decontaminated prior to performing maintenance. See *Section 3.3, Purging and Decontaminating the CP-80*, for instructions.
2. Ensure that the CP-80 has been disconnected from all pressure sources and depressurized prior to performing maintenance.

Disassembly

Figure B2: CP-80 With Vortex Mixer Maintenance Diagram

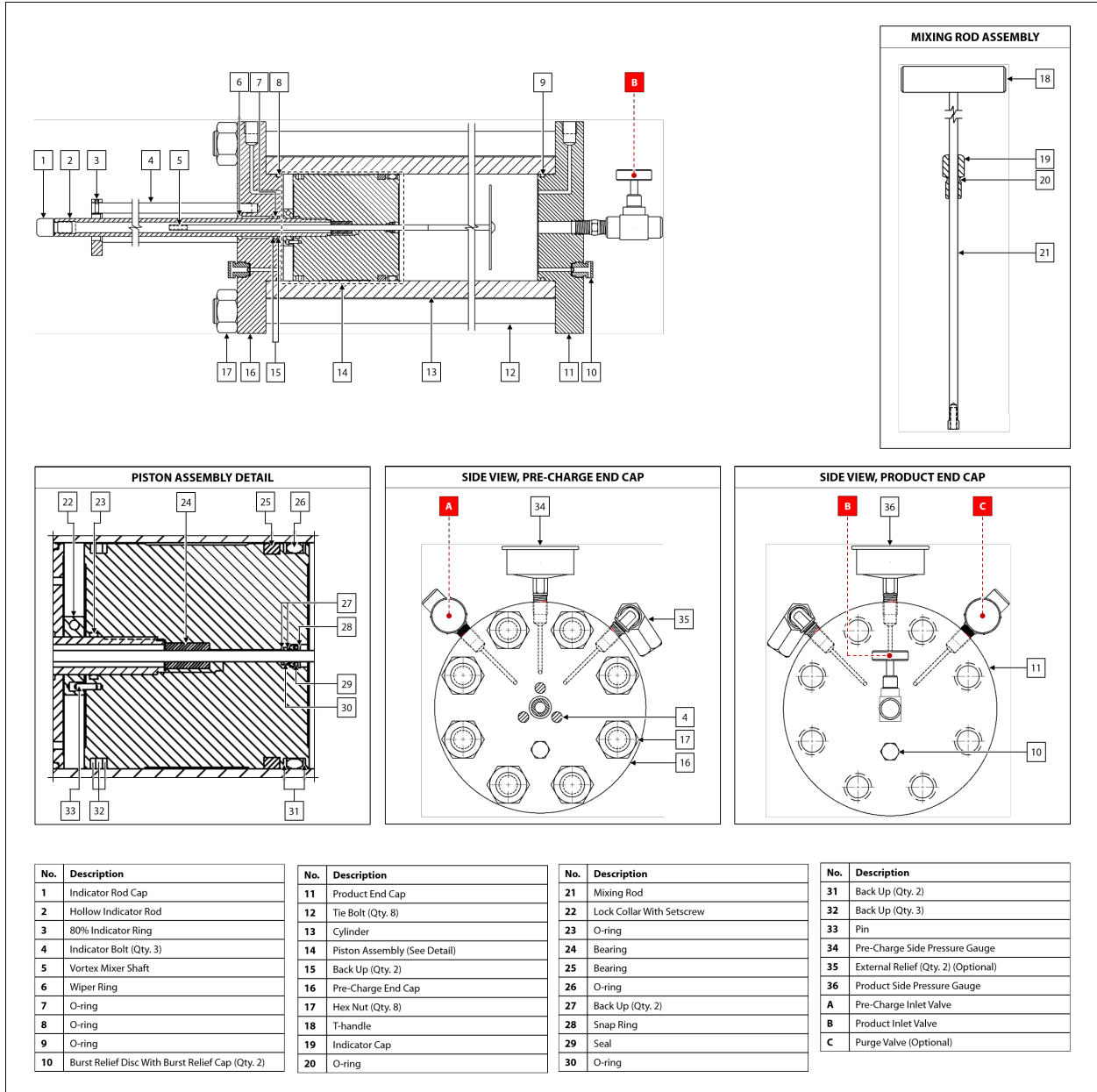

3. Remove the valves and pressure gauges from the end caps.
4. Loosen the setscrews in the 80% indicator ring, and then remove the ring from the indicator bolts. Take care not to misplace the setscrews.

5. Unscrew the eight (8) hex nuts from the tie bolts.
6. Carefully remove the pre-charge end cap from the cylinder by sliding it off the hollow indicator rod.
7. Unscrew the indicator bolts from the pre-charge end cap.
8. Holding the hollow indicator rod, carefully remove the piston assembly and vortex mixer shaft from the cylinder.
9. Carefully remove the vortex mixer shaft from the piston assembly.
10. Loosen the setscrew in the piston lock collar, and then unscrew the hollow indicator rod from the piston assembly, taking care not to misplace the pin that aligns the lock collar with the piston.
11. Remove the indicator cap from the hollow indicator rod, and then replace the O-ring. Return the cap to the hollow indicator rod.

End Caps

12. Remove the O-ring from the product end cap.
13. Remove the O-rings, back ups, and wiper ring from the pre-charge end cap.
14. Carefully clean and dry the end caps.
15. Install a replacement O-ring to the product end cap.
16. Install a replacement wiper ring and replacement O-rings and back ups to the pre-charge end cap.
17. As necessary, maintain the valves. To perform maintenance on the valves, refer to the *Installation, Operation, and Maintenance (IOM) Manual* for the valves for instructions.
18. If the CP-80 is equipped with burst relief discs, replace the burst relief discs. Refer to the *Installation, Operation, and Maintenance (IOM) Manual* for the burst relief discs for instructions.

Piston Assembly

19. Remove the back ups, O-rings, bearings, snap ring, and seal from the piston.
20. Carefully clean and dry the piston.
21. Install replacement back ups, O-rings, bearings, and a replacement seal to the piston.
22. Inspect the snap ring for damage or wear. Replace as necessary.
23. With the lock collar installed, screw the hollow indicator rod into the piston.
24. Assemble the piston to the lock collar by aligning the pin in the lock collar with the pin hole in the piston.
25. Tighten the setscrew in the lock collar to secure the lock collar to the piston.

Vortex Mixer

26. Replace the O-ring on the indicator cap on the mixing rod.
27. Carefully wipe down and dry the vortex mixer shaft and paddle.
28. Closely examine the polished and honed surfaces of the vortex mixer shaft and paddle, as scratches or pits may cause the seals to leak. If scratches or pits are present, the unit may need to be repaired or replaced. Contact Welker for service options.
29. Carefully insert the vortex mixer shaft through the piston into the hollow indicator rod.

Cylinder

30. Carefully wipe down and dry the inside of the cylinder.
31. Closely examine the polished and honed surfaces of the cylinder, as scratches or pits may cause the seals to leak. If scratches or pits are present, the unit may need to be repaired or replaced. Contact Welker for service options.

Reassembly

32. Carefully install the cylinder to the product end cap.
33. Following a cross-bolting sequence, install the tie bolts to the product end cap (*Figure B3*).

Figure B3: Cross-Bolting Sequence

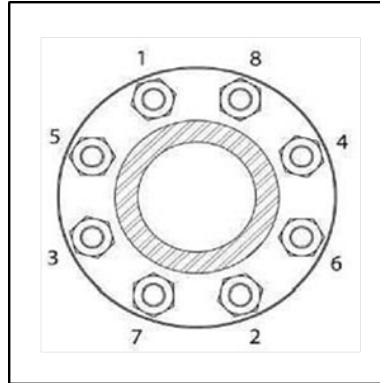

34. Holding the hollow indicator rod, insert the piston assembly with vortex mixer shaft into the cylinder.
35. Install the pre-charge end cap to the hollow indicator rod, and then carefully push the pre-charge end cap down to the cylinder. Ensure that the end cap fits onto the tie bolts.
36. Following a cross-bolting sequence, install the hex nuts to the tie bolts, and then tighten the hex nuts to the appropriate torque (*Figure B3* and *Table B1*).

Table B1: Torque Specifications for Tie Bolts

Tie Bolt Diameter	Foot-Pounds (ft•lb)	Kilograms per Meter (kg/m)
$\frac{7}{8}$ " or 1"	55–65	7.60–8.98

37. Screw the indicator bolts into the pre-charge end cap.
38. Install the 80% indicator ring to the indicator bolts.
39. Tighten the setscrews in the 80% indicator ring to secure it to the indicator bolts.
40. Ensure that the hollow indicator rod is centered within the 80% indicator ring. As necessary, loosen and tighten the setscrews until the hollow indicator rod is centered.
41. Return the valves and pressure gauges to the end caps.
42. Leak test the CP-80. See *Section 3.2, Leak Testing the CP-80*, for instructions.
43. Maintenance is now complete.

